

Performance Divergences of Axially Grooved Heat Pipes with Narrow Channels during Inclination Ground Testing

Nadjara dos Santos, Valeri Vlassov*, Jorge Bertoldo Junior and Olga Kchoukina

National Institute for Space Research, S.J.Campos-SP, Brazil

Abstract

Heat pipes are extensively used in space applications for spreading the heat of electronic equipment along the satellite structural panels. For such utilization, the ammonia-filled axial aluminum grooved heat pipes are commonly used by embedding them into the honeycomb panels. Two-core heat pipes provide the redundancy and appropriate fitting between two face sheets of the panel. For typical panel thickness of ~20mm, the diameter of vapor core is relatively small, about 6 mm. During satellite thermal vacuum tests, the entire satellite shall be precisely leveled in order to keep the conditions for horizontal heat pipes working ability. In large thermal-vacuum chambers, such high precision horizontal pre-leveling may be lost when the chamber is under vacuum: bottom shroud may slightly be deformed under atmospheric pressure. Therefore, it is important to know the possible heat pipe performance divergences under small angles in both favorable and unfavorable inclinations. The present study releases experimental data of the inclination tests of a two-core ammonia heat pipe in wide range of negative and positive inclinations under different heat loads. Both, steady state and transient start-up performance were assessed. It was found that under some small favorable inclinations the heat pipe presents some unexpected anomalies in the total thermal resistance, while under small unfavorable the heat pipe works well. At start up, some anomalies were observed under small inclinations. The temperature overshoots may be of two different types: due to dry-out or due to eventual over-flooding of the evaporator section. The initial transient behaviors are very similar however the consequences may be very different for the case of ground satellite testing.

Keywords: two-core heat pipe; ground testing; inclination tests; satellite thermal control

1. INTRODUCTION

In many space applications, the heat pipes are embedded into the honeycomb panels to spread heat dissipated by on-board equipment that mounted on these structural panels. For such utilization, the ammonia-filled aluminum axially grooved heat pipes are commonly used. The heat pipe, embedded into honeycomb panel, makes a strong thermal coupling of the hot equipment interface area with the more cold free area of the panel.

Ammonia heat pipes have a very high heat transport capability and usually operate far from its capillary limits in the structural panels. A small diameter heat pipe may provide the needed heat transport performance to dissipate heat load from the electronic equipment.

During satellite thermal vacuum tests, the entire satellite shall be precisely leveled in order to keep the conditions for horizontal heat pipes working ability. In large thermal-vacuum chambers, such high precision horizontal pre-leveling may be lost when the chamber is under vacuum: bottom shroud may slightly be deformed under atmospheric pressure. Therefore, it is important to know possible heat pipe performance divergences under small angles in both favorable and unfavorable inclinations.

In some panels, the HP may appeared be positioned vertically. In this case if heat load is

located in the bottom part of the HP, the HP will operate in so named reflux mode. The behavior of the HPs in such vertical position or in favorable inclination positions is different than in OG or horizontal leveling.

In 1991 Ali Cetin Gurses etc [1] studied experimentally gravity-assist mode of water-filled thermosiphone of relatively small inner diameter of 15 mm and length of 1930mm. They found that the effective heat transfer rate strongly depends on the inclination angle, and the maximum heat transfer capability is observed in favorable inclination above about 30 degrees at 20 C of sink temperature; at inclinations between 30 and 90 the heat transfer rate is not changed.

C.K. Loh etc in 2005 [2] presented results on inclination test of short HPs (L=200mm) of different capillary structures and small outer diameters of 4, 5, and 6mm. Steady-state performance curve were revealed at inclination ranged from -90° to +90°. Grooved HP did not work at unfavorable negative inclinations, while in positive inclination the performance of all HPs were similar.

Vikas Kumat etc in 2007 [3] published inclination test results for wire screen HP being heated by forced convection (such heating prevents temperature overshoot on dry-out but not representative for space applications). HP of 800 mm length and inner diameter of 22 mm was tested at

gravity-assist mode at positive inclinations. They reveal that the heat transport rate increases as the tilt angle of heat pipe increases from 15° to 25°, and it decreases beyond 25°.

Zhen-Hua Liu in 2010 [4] in the study related to nano-fluid influence revealed also particular experimental results of inclination test in gravity-assist mode within the 0°-90° range. The investigated HP is of 350 mm length and 8 mm OD and has spirally rectangular micro-grooves. They concluded that the inclination angle has a strong impact on the condensation heat transfer coefficient (HTC). As long as the heat pipe has inclination 30° or more, the condensation HTC can jumpily improve and increase maximally 2 to 8 times at the low heat fluxes, compared with those of the horizontal case. However, the maximum heat flux for inclined heat pipe can increase doubly and the inclination angle itself has only weak effects on the maximum heat flux. Inclinations below 30° were not studied.

Senthilkumar R. etc [5] in 2012 tested a HP of 0.6 m length and 17.6 mm ID with a stainless steel wrapped screen as a capillary structure by a similar way. Steady state performances were obtained at inclinations ranged from 0 to 90° with the interval of 15°. Minimal thermal resistance of HP was observed at 15 to 45° inclination having the gain about 25% better than at horizontal position.

The inclination tests with a HP charged with dilute aqueous solution of n-Pentanol were performed by Senthilkumar in 2011 [6]. This working fluid have a positive surface tension gradient with temperature.

All above studies were not performed in very small positive and negative inclinations <5°, and no any transient start-up performances were investigated at any inclinations

The importance of study of transient start-up performance at different inclination of HP for space application was highlighted by Yasuko Shibano and Hiroyuki Ogawa in 2015 [7]. They studied thermal behavior of an Ω and rectangular groove ammonia AGHPs on the ground in low temperature (-60°C) and at inclination of 0, 5, 30, 60 and 90° in the reflux mode. Both HPs are of 1m length and ~10 mm OD. They presented original results related to an anomaly observed on start-up at 30°, that seems never were published before (Fig 5 in their paper). They commented that “We do not have any explanation for these phenomena at the present”.

Most recently the inclination study for HPs was also performed by Jantung Ku [2018]

During satellite ground testing all engineers and managers concern about if everything runs well. When a sensitive instrument, which attached to HP for cooling, switched on for testing, everybody expect that HP will work normal and instruments temperature goes up and when soon stabilizes. But

what to do if it does not happened and the temperature continues to rise? What the decision shall be make immediately - stop the testing or continue? If satellite is in a big vacuum chamber, any test chronogram delay means lost money and nervous.

Unfortunately, this issue of HPs operation in gravity, especially in transient modes, does not get enough attention. It is also important in such experimental studies to set a HP in an equivalent condition as it takes place in the satellite structure. For example most (may be about 90 %) of experimental studies on HP performance were conducted following the classic setup scheme: three HP sections: evaporator, adiabatic and condenser with thermally well-coupled effective heat sink. It is absolutely not real situations for HP inserted in structural panels of satellites submitted to the ground testing. The peculiarities are the following: no adiabatic section; no power heat sink; no high heat flux available on start-up due to high thermal inertia of attached objects.

2. TWO-CORE HEAT PIPE TEST SETUP

The best way to arrange the heat pipe into the panel is when the heat pipe flanges fit the panel thickness and have a good thermal contact with the face sheets. When the panel thickness is equal or above 20 mm, the two-core ammonia heat pipes can be used; the cross-section of such a typical heat pipe is shown in Fig. 1.

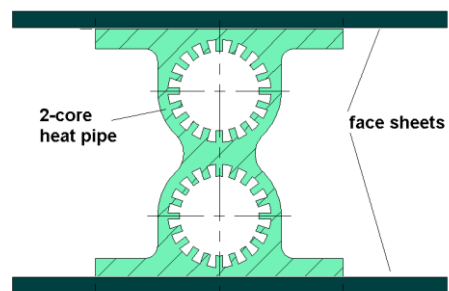

Fig. 1. Two-core heat pipe inserted into honeycomb panel

Such type of heat pipe has a relatively small diameter of vapor channel. Some excess of liquid phase in the HP takes place at ambient temperature due to usual charging proceeding; at the gravity conditions the upper groove also may be dried when HP stay in horizontal or near-horizontal position. In a HP of large diameter such an excess of liquid phase forms a puddle at the bottom zone of the vapor channel. However in small-diameter HP such a puddle configuration may be not stable. If liquid fills

some space of the vapor channel near HP extremes, it develops the capillary pressure of about 20 Pa, which is slightly higher than the static pressure of the puddle up to ~ 2.3 mm of height. The puddle transforms in slugs which may delay and affect the start-up behavior.

Experimental HP has two cores, charged with ammonia and has rectangular grooves. It is of 19mm height and 730mm length. Vapor channel diameter is about 6 mm. The test setup is composed of a motorized inclination table, data acquisition system, heating block and high-precision digital inclinometer, as shown in Fig.2.

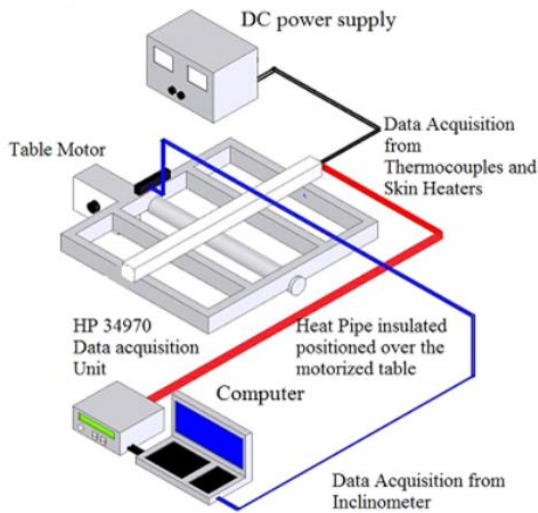

Fig. 2. Experimental setup.

The 18 T-type thermocouples, installed along the HP length, measure the temperatures of each core. The heating and measuring blocks also have 7 thermistors for measuring redundancy. The thermocouples and thermistors layouts are shown in Fig. 3.

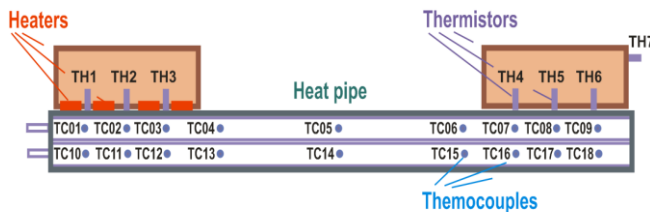

Fig. 3. HP instrumentation.

Heaters are positioned at the 0-200 mm zone. Natural convection provides slight cooling of HP at rest of its length. Such the test setup represents typical thermal condition for HPs installed in a satellite structure and operating during ground testing.

3. STEADY-STATE PERFORMANCE IN SMALL INCLINATIONS

Usually the heat pipe is filled with a slight excess of fluid in order to assure the full priming of all grooves at low operating temperature. Under room or hot temperature, the liquid expands and partially occupies the vapor core. Such an excess of liquid volume forms a slug that may stay in the vapor core at one or both HP extremes when HP still not in operating.

Such the liquid slug may disappear after start-up with a significant delay or may even stay if input power is low. This meta-stable slug can disturb the steady-state performance and sometimes turns the temperature profiles be opposite as expected. For example, it is well known that slight positive (favorable) inclination shall guaranty best performance and small thermal resistance. It is not confirmed by the temperature profile shown in Fig. 4: it is clear that internal heat transfer coefficient (HTC) in the evaporator zone is reduced and overall HP resistance is increased, in spite of HP positive inclination. The reason is a meta-stable liquid slug trapped at the extreme of the evaporator vapor channel.

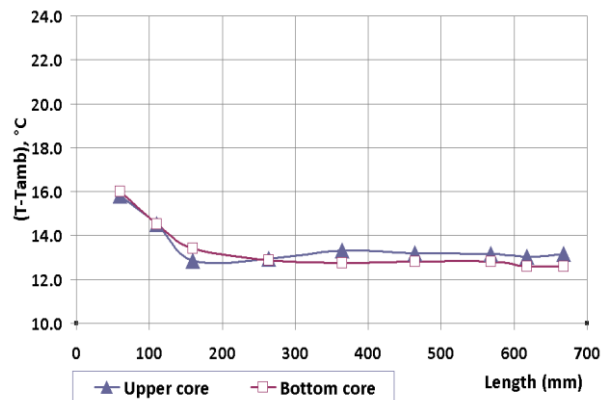

Fig.4. Distortion of the temperature profile under favorable inclination of +2 degrees and heating power of 15 W (trapped slug).

From the other hand, in small negative unfavorable inclination it may be expected a partial drying of evaporator grooves. The T profile shown in Fig. 5 presents an opposite effect than expected.

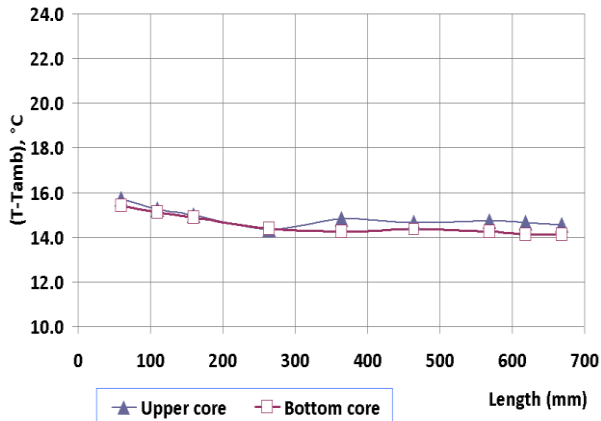

Fig. 5. High equivalent conductance of the HP under unfavorable inclination of -2 degree and 15W.

The slug either disappears or moves into condenser extreme. The slug helps both lower and upper grooves priming and no groove drying occurs in the evaporator zone: the temperature profile is very smooth.

4. START-UP AT SMALL INCLINATIONS

Nominal startup occurs at horizontal and near-horizontal HP position and usually does not present any anomaly, as shown in Fig 6

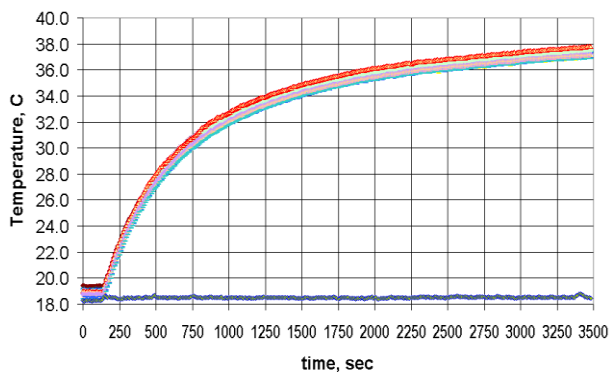

Fig. 6. Smooth nominal start-up, heat load is 20W, inclination is +0.3 deg..

Note, all temperatures run together and smoothly; the effective HP thermal resistance is low.

However in small favorable inclination, a liquid slug, developed in the vapor core at the evaporator extreme, may affect start-up behavior, as shown in Fig. 7.

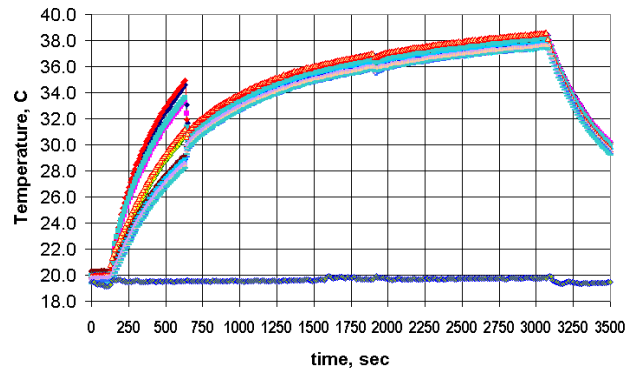

Fig. 7. Start-up with overshoot and delay of 630 sec; heat load is 20W, inclination is +2.5 deg..

After some delay the slug disappears and rest of startup goes smoothly. It may happened due to formation of bubble that expulse and disperse slug into vapor core; liquid drops move into the condenser zone entrained into the vapor flow.

It is interesting to note, that in [7] authors reported exactly the same effect observed in the ammonia HP of low diameter.

Such the start-up delay may provide a slight but unexpected temperature increasing on attached equipment during the ground test.

From other hand, in some conditions the liquid slug may be trapped and stay permanently even when HP achieve a steady-state mode. Figure 8 illustrates this case.

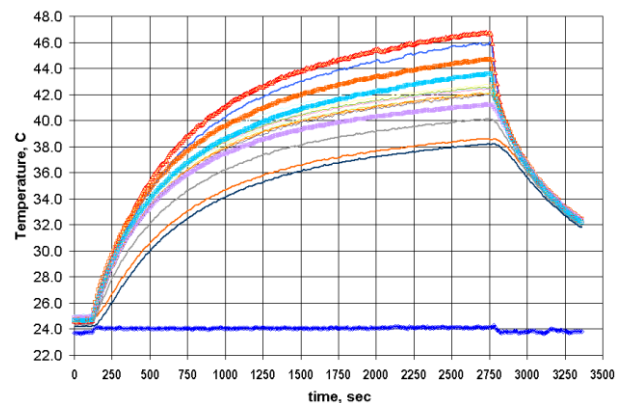

Fig. 8. Start-up with permanent overshoot; heat load is 20W, inclination is +1.5 deg..

Under small negative (unfavorable) inclinations the HP may be partially dried out at the evaporation zone and may present abnormally a high temperature transient, as shown in Fig 9.

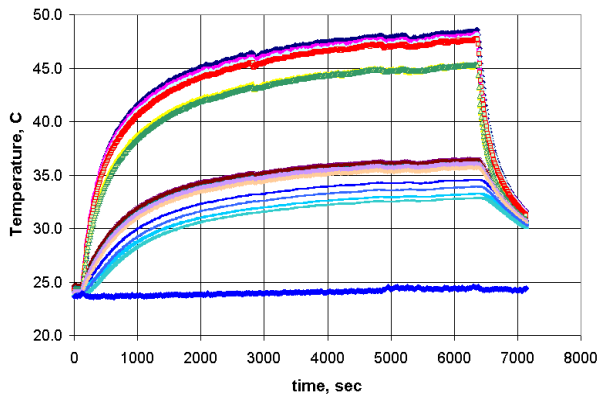

Fig.9. Dry-out under unfavorable inclination of -2 degree 15 W.

It is important to note, that the dry-out behavior in 1G condition is different than one at microgravity. When at the 0G condition the dry-out occurs, it usually makes the dried portion of the evaporator rapidly increases. An excess of liquid forms a slug that accumulates and moves toward the condenser end. At 1G condition under small negative inclinations, the excess of liquid forms a puddle at the HP bottom, which provides an additional path of the liquid return to the evaporation zone; such a puddle partly compensates a negative effect of the dry-out and does not allow of its full development. This partial dry-out is smoother than the fully developed 0G dry-out, and makes the transient curve behavior somewhat similar to one of the cases of overshoot under small positive inclinations (Fig 8).

5. START-UP AT REFLUX MODE

At vertical position the heat pipe may present an anomaly on transient behavior at start-up when heated from bellow. A liquid column that inevitably occupies the evaporation area before heating starts, completely or partly blocks the evaporation area and HP does not work for a certain time: a delay on HP start-up occurs which causes a temperature overshoot. When during heating the temperature difference in the liquid bulk achieves the boiling limit, vapor bubbles expel the liquid drops and vapor channel cleans up. Rapidly the intensive evaporation starts and temperature drops down; the overshoot recuperation takes place. Figure 10 illustrates this HP behavior. One can see the overshoot during first ~400 sec after heating initiation, when HP does not work, and then sudden recuperation to a nominal start-up transient.

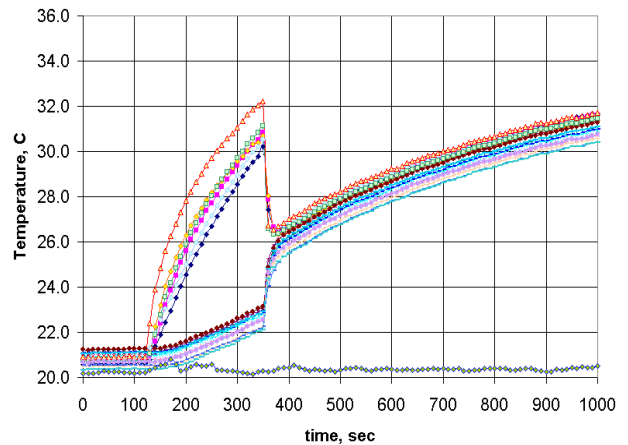

Fig. 10. Temperature overshoot during start-up of the heat pipe at vertical position (15W, 90 deg).

Usually, a minor delay takes place when the heat load is higher. Figure 11 illustrates this regularity for the heat load of 25 W compared to the previous case of 15 W: the delay is 110 sec versus 400 sec.

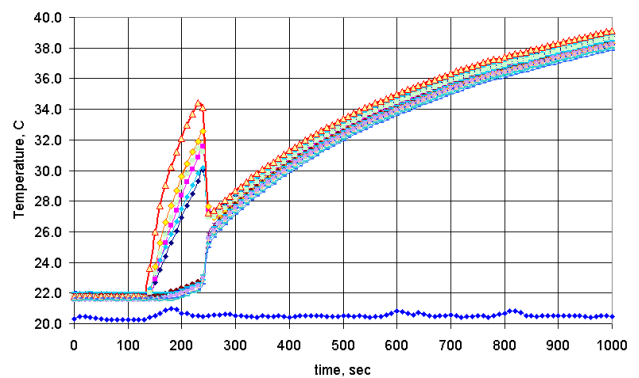

Fig. 11. Temperature overshoot during start-up of the HP at vertical position (25W, 90 deg).

In many satellite applications, the HPs are embedded in structural honeycomb panels where equipment electronic boxes are installed. When this box is switched on and starts its heating, the effective heat flux into the HP is relatively small due to high usual thermal inertia of the equipment. It is equivalent of stay-alone HP start-up at low heat load. Therefore, the overall tendency in real applications is a long delay before the temperature recuperation from the overshoot.

6. OVERSHOOT SUMMARY

Figure 12 shows a summary of conducted HP start-up tests. Temperature picks above nominal transient curves are given at the moments just before the overshoot recuperations as functions of HP inclination.

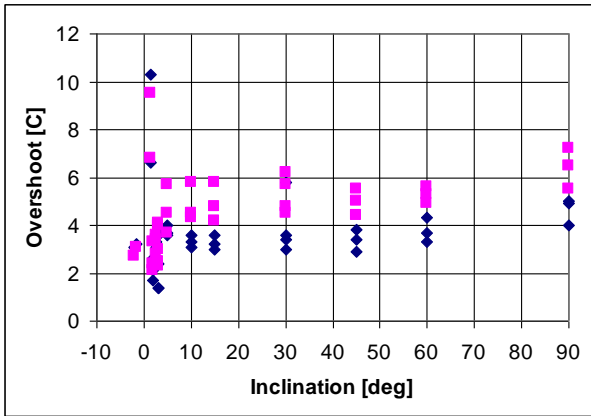

Fig. 12. Temperature overshoots summary.

The overshoot magnitudes lie between ~2C and ~10C. Maximal temperature overshoots were observed under small inclinations within ± 3 degrees. Elevated overshoots were observed in the reflux modes, and moderate overshoots - under moderate positive inclinations in the range of ~5 to 60 degrees.

Next figure reveals delays on overshoot recuperation before HP starts to operate regularly.

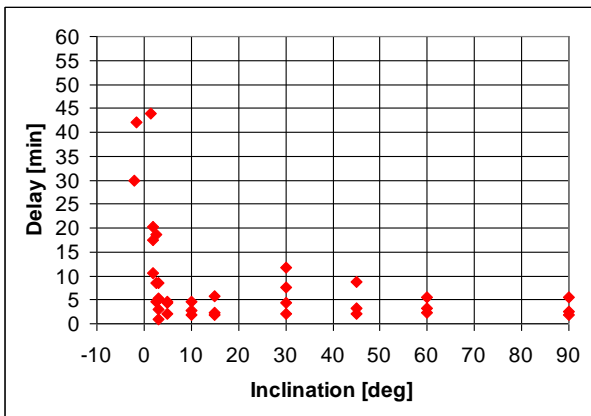

Fig. 13. Temperature delays on overshoot recuperations summary.

Most significant delays, more than half an hour, were observed at some small inclination angles within ± 3 degrees. In high positive inclinations, more than 5 degrees, a usual delay may last from about 2 to 10 minutes.

Total more than 60 start-up tests have been completed. Certainly, not all start-up tests yield overshoot behavior; depending of inclination, many start-up demonstrated smooth and nominal transient, shown, as an example in Fig. 6. In some cases, on test repetition, the start-up behavior may change, and a nominal start-up may turn to the overshoot behavior under absolutely the same test

conditions. Table 1 demonstrates summary of all conducted tests as functions of the HP inclination and heat load. The experimental data are presented in the form of rough evaluation of probability of the overshoot occurrence. For example, 0 - overshoot is never observed, 1 - always happened; 0.5 - one day - yes, another day - not. Sign means type of overshoot: positive - is due to flooding, and negative - is due to dry-out.

Table 1. Estimation of overshoot type and probability.

Incl[deg]-Q	15W	20W	25W
-3.0	-1	-1	-1
-2.0	-0.5	-0.5	-0.5
-1.5	0	0	-1
-1.0	0	0	0
-0.6	0	0	0
-0.3	0	0	0
0.0	0	0	0
+0.3	0	0	0
+0.6	0	0	0
+1.0	0	0	0
+1.5	0.5	0	0
+2.0	0	1	1
+2.5	N/A	1	1
+3.0	1	1	1
+5.0	N/A	1	N/A
+10	N/A	1	1
+15	1	1	1
+30	1	1	1
+45	1	1	1
+60	1	1	1
+90	1	1	1

7. FLOODING OR DRY-OUT OVERSHOOT?

The aim of this study is to try to clarify a possible HP behavior under different inclination during satellite ground testing in a vacuum chamber. The thermal control specialist shall be able to recognize, just after electronic box or instrument is switched on, if attached HP performs well or not. It can be only possible by the observation and evaluation of peculiarities of the temperature rising during start-up.

Unfortunately, there is no a simple answer on this matter. Figure 13 shows first ~15 minutes of a transient start-up of the HP under 15W heat load inclined either +2.0 or 0 or -2.0 degrees. In this figure, TC#nm means nominal start-up, measured by corresponding thermocouple, TC#dr - overshoot due

to dry-out, and TC#fl - overshoot due to evaporator partial flooding.

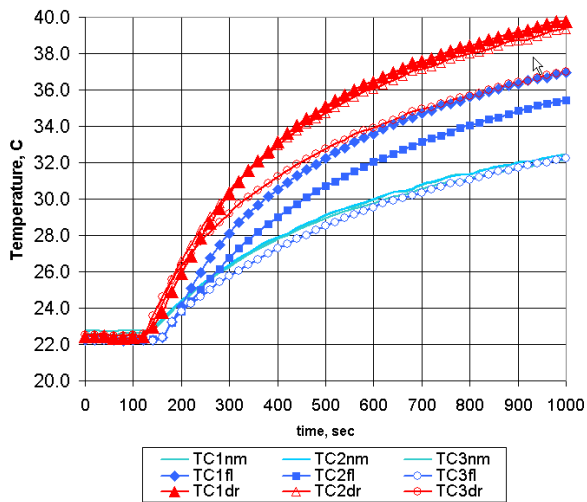

Fig. 13. Superposition of temperature rise in evaporation zone in cases of nominal start-up, overshoot due to dry-out and overshoot due to flooding.

One can see - all behaviors are very similar and if no reference temperature is provided, it is very difficult to distinguish nominal transient or overshoot transient. If no information of real HP inclination is available, it is even more difficult to distinguish the type of the observed overshoot: either due to evaporator flooding (positive inclination, the satellite test can continue) or due to dry-out (negative inclination of HP failure, the satellite test shall be interrupted).

The authors see the only way to at least try to distinguish nominal or overshoot HP behavior - is to install at least two temperature sensors near the HP evaporation region. As it seen from the graph, at nominal start-up all temperatures run together, while on overshoot they rise at different rate.

However the question how to recognize a type of overshoot during first 10-20 minute after switching on of the heat load - is still an open point and need further investigations.

8. CONCLUSIONS

Extensive studies were performed on steady-state and start-up transient performance of two-core ammonia axially groove HPs of a relatively small diameter of vapor channel. Transient behavior was studied in details on the base on more 60 conducted tests. Under some small inclinations a heat pipe may presents unexpected temperature anomalies. Such temperature overshoots were investigated and characterized in terms of

overshoot magnitudes and delay on overshoot recuperation to nominal HP start-up.

ACKNOWLEDGEMENT

Authors acknowledge the CNPq organization grant 311347/2015 and CAPES grant 1456650/PNPD for the support of the present research

NOMENCLATURE

HTC : Heat Transfer Coefficient ($W/m^2/K$)
 HP : Heat Pipe
 N/A : not available
 T : Temperature (K)
 TC : Thermocouple

REFERENCES

- [1] Ali Cetin Gurses, C.Cannistraro and Levent Tezcan. The inclination effect on the performance of water-filled heat pipes. *Renewable Energy* 1 (5/6) (1991) 667-674
- [2] C.K. Loh, Enisa Harris and D.J. Chou. Comparative Study of Heat Pipes Performances in Different Orientations. *Proc. of 21st IEEE SEMI-THERM Symposium*, San Jose, CA, USA (2005) 1-5
- [3] VIKAS KUMAR, D. GANGACHARYULU and RAM GOPAL TATHGIR. Heat Transfer Studies of a Heat Pipe. *Heat Transfer Engineering*, 28(11) (2007) 954-965
- [4] Zhen-Hua Liu, Yuan-Yang Li, Ran Bao. Thermal performance of inclined grooved heat pipes using nanofluids. *International Journal of Thermal Sciences* 49 (2010) 1680e1687
- [5] Senthilkumar R, Vaidyanathan S, Sivaraman B. Effect of Inclination Angle in Heat Pipe Performance Using Copper Nanofluid. *Procedia Engineering* 38 (2012) 3715 - 3721
- [6] Senthilkumar, R., Vaidyanathan, S. and Sivaraman, B. Performance investigation of heat pipe using aqueous solution of n-Penthanol with different inclinations. *Journal of Mechanical Science and Technology*. 25(4) (2011) 923-929.
- [7] Yasuko Shibano¹ and Hiroyuki Ogawa¹. Thermal Behavior of Axial Grooved Heat Pipe under Gravity: Dependence of Groove Shape and Orientation. In: *Proc. of 45th International Conference on Environmental Systems*, ICES-2015-126, 12-16 July 2015, Bellevue, Washington, (2015)
- [8] V. Barantsevith, O. Golovin, K. Goncharov, A. Orlov, V. Buz, Investigation performance of axial grooved heat pipes with high thermal capacity, in: *Proc. of 12th International Heat Pipe Conference*, Moscow, Russia, (2002) 489-494.

- [9] R. Schlitt, Performance Characteristics of Recently Developed High-Performance Heat Pipes, *Heat Transfer Engineering*, 16 (1) (1995) 44-52.
- [10] Jorge Bertoldo Junior, Valeri V. Vlassov, Gino Genaro, Ulisses Tadeu Vieira Guedes. Dynamic Test Method to determine the Capillary Limit of Axially Grooved Heat Pipes. *Experimental Thermal and Fluid Science*. 60 (2015) 290–298.