

# Study of hydrophobicity and the surface flashover dependence in UHMWPE dielectric modified by PIII

A R Silva<sup>1,2</sup>; J O Rossi<sup>1</sup>; M Ueda<sup>1</sup>; L P Silva Neto<sup>1</sup>

<sup>1</sup> Associated Laboratory of Plasma, National Institute for Space Research – INPE

<sup>2</sup> Associated Laboratories of Materials Engineering and Sensors – INPE

São Jose dos Campos, SP, Brazil.

Contact: ataide@plasma.inpe.br

*Polymer dielectrics are used in several areas. Previous works show a great influence of hydrophobicity with the breakdown voltage on the surface of some dielectrics. The use of energetic particles to modify polymer surfaces is widely used method. In this work, the ultra-high molecular weight polyethylene (UHMWPE) has been modified by plasma immersion ion implantation (PIII) and studied for using as dielectric testing sample. After treatment by PIII, a formation of carbon chains with cross-links was obtained on the surface, with features similar to the diamond like carbon (DLC) films. Raman spectroscopy was used to detect the structural information of surface after the nitrogen PIII.*

Keywords: UHMWPE, Plasma Immersion Ion Implantation, Hydrophobicity, surface flashover, dielectric

## 1. Introduction

Previous works have shown a great influence of hydrophobicity on surface breakdown voltage of some dielectrics [1-2]. The use of energetic particles to modify polymer surfaces is a well-known method [3]. The plasma immersion ion implantation (PIII) treatment was applied using a newly modified Blumlein pulser. The ultra-high molecular weight polyethylene (UHMWPE) is used in electronic industry as a dielectric material for insulation. This polymer presents a high dielectric constant and a high voltage applied across its surface can cause flashover. Changes of tribological properties by PIII treatment can increase the HV BD on polymer surface.

## 2. Experimental part

The redesign of a Blumlein pulser was carried out to perform PIII process with nitrogen and the operation of this system is described elsewhere [4]. Negative pulses of 20kV/5 $\mu$ s/100Hz were applied during the PIII process. Before the treatment, a low pressure of 1x10<sup>-3</sup> Pa was achieved to clean the vacuum chamber. Nitrogen plasma was produced with a treatment pressure of 0.3 Pa. Samples of UHMWPE used to test the method had 20 mm diameter and 3 mm thickness. They were sanded, polished with diamond paste and cleaned-up by isopropyl alcohol before the nitrogen PIII treatment. A steel grid was used to attract the ions to the polymer surface. Raman spectroscopy was employed to detect the structural information on polymer surface after the treatment. The hydrophobicity was assessed by measurements of contact angles using distilled water. For the HV BD tests, we used an LC oscillatory half sine wave circuit as shown in Fig. 1. This circuit consists of a discharge of two capacitors of 1 $\mu$ F/600 V through the primaries of two car ignition coils connected in parallel. In order to generate HV pulses the secondary windings of both coils are biased positively and negatively as the picture in Fig. 2 gives a general view of this circuit. With full DC charging voltage, a differential pulse peak of about 60 kV is applied across positive & negative terminals. The pulse duration is of the order of 100  $\mu$ s and normally the breakdown occurs near the peak as shown in Fig. 3 for an air gap flashover. Dividing the differential peak of about 10 kV by the gap distance of approximately 3 mm gives a BD strength

of the order 3 kV/mm (see Fig. 3 again). For polymeric samples, the BD strength is calculated in this case by using their thickness.

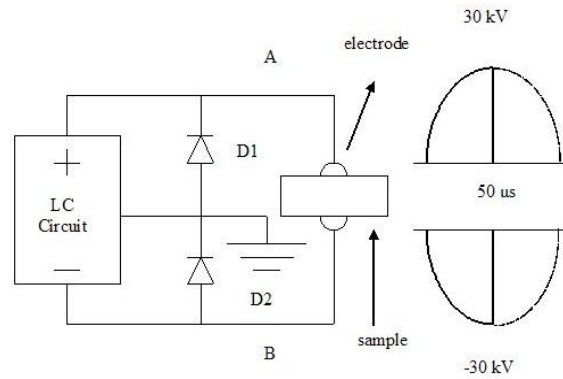


Fig. 1. Electrical scheme of the BD testing circuit used.



Fig. 2 – General view of the BD circuit, showing the ignition coil, the sample holder and the high voltage storage system.

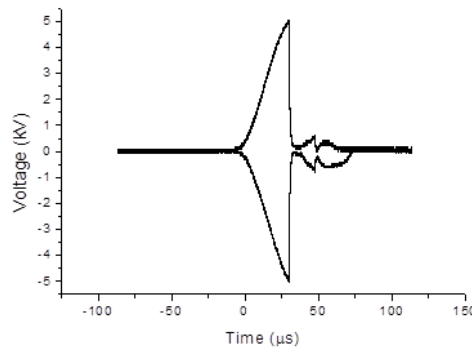
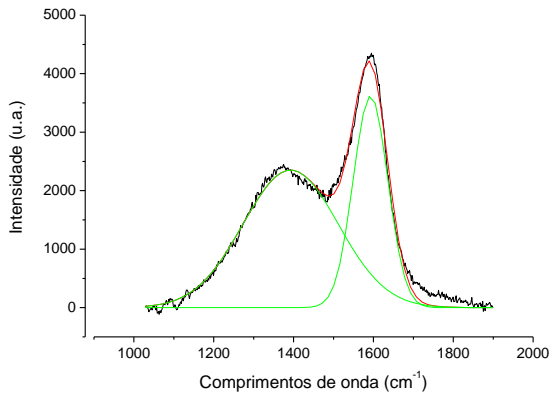


Fig. 3 – The results of flashover test confirming the BD of 3kV/mm in air.

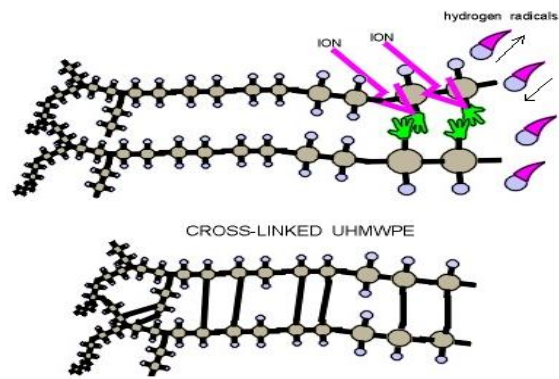
### 3. Results and discussion

The treatment of UHMWPE with nitrogen PIII was performed with success. After PIII treatment, carbon chains with cross-links were formed on the surface as shown by Raman spectroscopy in Figure 4, which is similar to the diamond like carbon (DLC) films [5]. To explain that, Fig. 5

illustrates the structural modification of cross-link process that occurred due to the impact of nitrogen ions. Note that hydrogen radicals are removed from carbon chains and, consequently, links of carbon-carbon and cross-linked chains are formed.

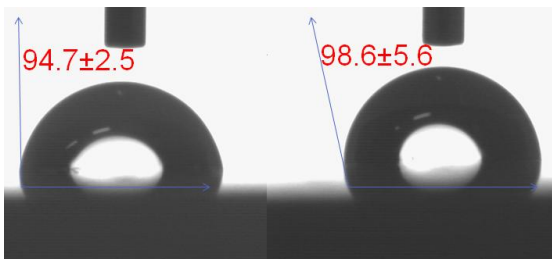


**Fig. 4** – Analyses by Raman spectroscopy on treated surface indicate formation of DLC structure type.

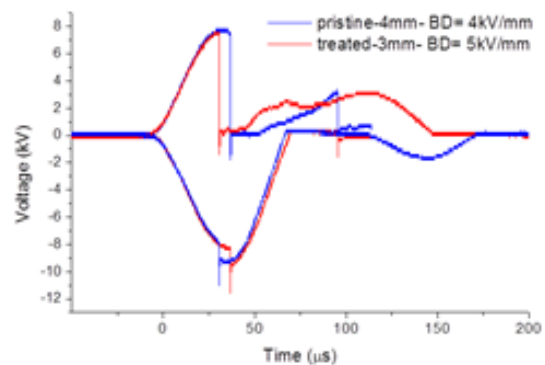


**Fig. 5**– The images above show a schematic of the cross-linking process during the nitrogen PIII (adapted from [http://www.ofthalmotaubate.com.br/img/pics/crosslinking\\_pic2.jpg](http://www.ofthalmotaubate.com.br/img/pics/crosslinking_pic2.jpg)).

As shown in Fig. 6, the virgin sample (left) presented hydrophobic characteristics and the contact angle measured after PIII treatment (right) showed a small increase, varying from 94.7° to 98.6°. On the other hand, during the flashover test, a significant increase in the surface VD voltage was observed changing from 4 kV/mm for pristine to 5 kV/mm for treated sample as shown in Fig.7. Although the BD discharge had happened practically at the same differential voltage peak of about 16 kV for both samples, it is important to note that the pristine sample used for comparison had a bigger thickness of 4 mm, which gives a lower BD strength.



**Fig. 6** – Pristine (left) and treated (right) samples under contact angle measurements showing a small increase.



**Fig. 7** – The flashover tests on samples have showed an increase in the surface BD.

#### **4. Conclusions**

PIII process allowed changes in the surface characteristics of UHMWPE. Structural surface modifications are obtained (DLC formation) but no significant changes in hydrophobic characteristics were detected as DLC is typically hydrophobic, although the polyethylene also has small wettability. However, resistance to flashover voltage by electrical discharge on surface was measured with a significant increase of 25 % for the treated sample. Anyway, other polymer (PMMA) is going to be tested which has lower angle contact than UHMWPE.

#### **References**

- [1] **Wilson, M.P. ; Given, M.J. ; Timoshkin, I.V. ; MacGregor, S.J. ; Tao Wang ; Sinclair, M.A. ; Thomas, K.J. ; Lehr, J.M.**, Impulse-driven Surface Breakdown Data: A Weibull Statistical Analysis, **Tran. on Plasma Science**. Vol. 40, 2449–2456.
- [2] **Kirkici, Hulya; Serkan, Mert; Koppisetty, Kalyan** . Nano/Micro Dielectric Surface Flashover in Partial Vacuum. **Tran. D. and Elec. Ins.**, v. 14, p. 790-795, 2007.
- [3] **Lee, Yeonhee; Han, Seunghee; Lee, Jung-Hye; Yoon, Jung-Hyeon; Lim, Hyun Eui; Kim, Kang-Jin**, Surface studies of plasma source ion implantation treated polystyrene, **J. of Vacuum Sc. And Tech.**, Vol. A16, 1710-1715.
- [4] **Rossi, J. O.; Ueda, M.; Oliveira, R. M.**; Redesign of a HV Blumlein Pulser for Pulse Upgrade in The Microsecond Range, IEEE IPMHV conference, 264-267, 2008.
- [5] **Marcondes, A. R.; Ueda, M.; Kostov, K. G.; Beloto, A. F.; Leite, N. F.; Gomes, G. F.; Lepiensi, C. M.**; Improvements of Ultra-High Molecular Weight Polyethylene Mechanical Properties by Nitrogen Plasma Immersion Ion Implantation, **Braz. J. Phys.** [online]. 2004, vol.34, n.4b, pp. 1667-1672.

#### **Acknowledgements:**

**CAPES, CNPq, MCTI, AFOSR- USAF**